



وزارة البحث العلمي والتعليم العالي
Ministry of Higher Education and Scientific Research
جامعة عبد الحميد بن باديس مستغانم
Abdelhamid Ibn Badis University of Mostaganem
كلية العلوم والتكنولوجيا
Faculty of Science and Technology
Department of Electrical Engineering



THESIS

To obtain the degree of

MASTER EN ELECTRICAL ENGINEERING
Specialty: Systems of Telecommunications

Presented by

Abdelhafid BENAMEUR
Sayf Allah BELBAHI

**Indoor VLC Implementation for Medical Healthcare
information system**

Defensed in September 23rd ,2024 in front of the jury:

President	M.MERAH	PROF	Abdelhamid Ibn Badis University, Mostaganem, Algeria
Reviewer:	M.ABED	MCA	Abdelhamid Ibn Badis University, Mostaganem, Algeria
Supervisor :	H. BENOUDNINE	PROF	Abdelhamid Ibn Badis University, Mostaganem, Algeria

Academic Year 2023/2024

Acknowledgments

After more than five years in this faculty, we shared so many memories with our classmates, so we take this opportunity to thank every classmate who made our journey unforgettable, thanks for the good memories and the laughter.

We would like to also express our sincere gratitude to everyone who helped and contributed to this accomplishment, everyone who supported, and encouraged us to fulfil this achievement.

We would like to express our sincere gratitude to our supervisor, Prof. Hadjira Benoudnine, for her exceptional guidance, expert advice, and steadfast encouragement throughout this journey. Her enthusiasm for the subject and dedication to excellence have motivated us to exceed our limits and aim for the highest standards.

Our heartfelt thanks also go to the members of our thesis committee, Dr. ABED Mansour and Pr. MERAH Mustapha, for their insightful feedback and constructive criticism. Their contributions have greatly enhanced the quality of this work.

We would like to extend our gratitude to the University of Mostaganem Abdelhamid Ibn Badis for providing us with the essential resources, facilities, and laboratory access, which were instrumental in our research process. We also wish to express our special thanks to Takarli Bensaber, who manages the FabLab, for his invaluable support and assistance.

We also want to express our gratitude to our family; they have been with us until the end, showing their unconditional love and support, it is such heart-warming feeling to know that we made them so proud of us, proud of our success.

Of course i won't forget to dedicate a very special thanks to the club CSB, i don't know how my life would be if i wasn't part of such an amazing organization, so i would like to express my gratitude to all the CSB members, the old, the ORIGINALS, the new and the future ones.

Maybe we couldn't mention everyone, we are grateful that you were there behind us throughout the entire journey, to everyone we couldn't mention,

Thank you

In this project, we propose an indoor optical wireless communication (OWC) based on visible light communication (VLC) for healthcare applications, in particular, on the medical information systems.

The system is designed to reliably transmit medical data and biomedical signals, such as electroencephalogram (EEG) and electrocardiogram (ECG) signals, body temperature and blood pressure. The transmission system is based on the Raspberry Pi 4 because of its technical performance.

The quality of the transmission demonstrates the performance of the implemented system.

Keywords: OWC, VLC, EEG, ECG, Wireless communication, biomedical signals,

في هذا المشروع، نقترح نظام اتصال لاسلكي بصري داخلي (OWC) يعتمد على الاتصال بالضوء المرئي (VLC) لتطبيقات الرعاية الصحية، وخاصةً، على أنظمة المعلومات الطبية. تم تصميم النظام لنقل البيانات الطبية والإشارات الطبية الحيوية بشكل موثوق ، مثل إشارات تخطيط كهربية الدماغ (EEG) وتخطيط كهربية القلب (ECG) ودرجة حرارة الجسم وضغط الدم. يعتمد نظام النقل على Raspberry Pi 4 بسبب أدائه التقني. توضح جودة النقل أداء النظام المطبق.

الكلمات المفتاحية: OWC، VLC، EEG، ECG الاتصالات اللاسلكية، الإشارات الطبية الحيوية ،

Dans ce projet, nous proposons une communication optique sans fil (OWC) en intérieure basée sur la communication par lumière visible (VLC) pour des applications dans le domaine de santé, en particulier, pour les systèmes d'information médicale.

Le système est conçu pour transmettre de manière fiable des données médicales et des signaux biomédicaux, tels que les signaux d'électroencéphalogramme (EEG) et d'électrocardiogramme (ECG), la température corporelle et la pression artérielle.

Le système de transmission est basé sur le Raspberry Pi 4 en raison de ses performances techniques. La qualité de la transmission démontre les performances du système mis en œuvre.

Mots-clés : OWC, VLC, EEG, ECG, Communication sans fil, Signaux biomédicaux

Table of contents

Acknowledgment	i
Abstract	ii
ملخص	iii
Résumé	iv
Table of contents	v
List of figures	vii
Abbreviations	ix
General Introduction	1

Chapter 1: Optical Wireless communication Basic Principles

1.1 Introduction	3
1.2 Visible light in data transmission.....	3
1.2.1 OWC based on Visible light	4
1.2.2 Visible light communication (VLC) functional principle	5
1.2.2.a) Transmitter (Tx)	6
1.2.2.b) Receiver (Rx)	6
1.3 Optical Modulation techniques.....	7
1.3.1 OOK Modulation.....	7
1.3.3 CSK Modulation.....	8
1.3.4 GSSK Modulation	8
1.3.5 Optical Asymmetric Modulation.....	8
1.4 Source coding in OWC.....	9
1.4.1 NRZ (Non-Return-to-Zero) code	9
1.4.2 Manchester code.....	10
1.5 Advantages of indoor OWC	10
1.6 Indoor OWC Applications.....	11
1.7 Conclusion.....	12

Chapter 2: Medical information systems

2.1 Introduction	14
2.2 Overview of Healthcare Signals.....	15
2.2.1 Common Physiological Signals	15
2.2.1.1 Electroencephalogram (EEG) Signals.....	15
A. Electronic Components of Electroencephalogram.....	16
B. Brain Waves	18
C. Applications of EEG	19
D. Advantages of EEG	20
E. Limitations of EEG	20
2.2.1.2 Electrocardiogram (ECG) signals.....	22
A. Electronic Components of the ECG	22
B. ECG Waveform	22
C. Intervals and segmentation	23

Table of contents

D. Applications of ECG	23
E. Advantages of ECG.....	23
F. Limitations of ECG	24
2.2.1.3 Electromyography (EMG).....	24
2.2.1.4 Electrooculography (EOG).....	24
2.2.1.5 Photoplethysmography (PPG)	25
2.3 Importance of Physiological signals	25
2.4 Medical signal processing	25
2.4.1 Signal transmission	26
2.4.2 Signal compression	27
2.4.2.1 Analog-to- Digital Converter (ADC)	27
2.5 Conclusion	28

Chapter 3: Experimental Results

3.1 Introduction	30
3.2 VLC design and diagram	30
3.2.1 Materials and Software.....	31
3.2.1.1 Microprocessor (Raspberry Pi4).....	31
3.2.1.2 SD cards.....	31
3.2.1.3 Raspberry Pi 4 Software	32
3.2.1.4 Raspberry Pi 4 access	33
3.2.1.5 Arduino Board	33
3.2.1.6 LED	33
3.2.1.7 Photo detector	34
3.3 Indoor VLC system design and experiment	35
3.3.1 Indoor VLC Transmitter (Tx).....	35
3.3.2 Indoor VLC Receiver (Rx)	35
3.4 Data transmission and synchronisation	36
3.4.1 Data Transmission	36
3.5 NRZ Encoding	36
3.6 Communication protocol	37
3.6.1 Data synchronization between transmitter and receiver	38
3.6.2 Data Transmission	38
3.6.3 Data Reception	39
3.7 Experimental results	41
3.7.1 Results discussion and Performance improvement	43
3.8 Conclusion	43
General Conclusion	44

- Fig 1.1 RONJA (Reasonable Optical Near Joint Access)
- Fig 1.2 A Photophone receiver and headset
- Fig 1.3 Electromagnetic spectrum
- Fig 1.4 Visible Light communication (VLC) block diagram
- Fig 1.5 Example of Data Transmission on free space
- Fig 1.6 Example of Non returns to zero code
- Fig 1.7 Example of Manchester code
- Fig 2.1 Example of EEG Signal
- Fig 2.2 10-20 system of electrode placement
- Fig 2.3 EEG Brain Waves
- Fig 2.4 EEG frequency bands
- Fig 2.5 Example of an ECG signal recorded
- Fig 2.6 ECG Waveform
- Fig 3.1 Schematic diagram of a simplex digital transmission system
- Fig 3.2 Raspberry Pi 4 Card
- Fig 3.3 Example of 32 GB SD card
- Fig 3.4 Arduino UNO Board
- Fig 3.5 The Electroluminescent Diode (LED) used in the experimental prototype
- Fig 3.6 Example of Photovoltaic cell
- Fig 3.7 Transmitter part of the Indoor VLC system
- Fig 3.8 Experimental design of the receiver in the of the Indoor VLC system
- Fig 3.9 Example of a binary sequence presented by the LED
- Fig 3.10 Short-Range Optical Wireless Communications Layers
- Fig 3.11 Indoor OWC system communication protocol
- Fig.3.12 Reception diagram
- Fig 3.13 Experimental prototype
- Fig 3.14 Transmission process of the Text

Table 3.1 Performance evaluation of Text transmission

Page 42

ADC: Analog to Digital Converter
ADHD: Attention Deficit Hyperactivity Disorder
AM: Amplitude Modulation
ASCII: American Standard Code for Information Interchange
BCIs: Brain Computer Interfaces
CSK: Color Shift Keying
ECG: Electrocardiogram
EEG: Electroencephalogram
EMG: Electromyogram
EOG: Electrooculogram
FDM: Frequency-Division Multiplexing
FM: Frequency Modulation
fMRI: Functional Magnetic Resonance Imaging
FSO: Free Space Optical
GSSK: Generalized Space Shift Keying
HHI: Heinrich Hertz Institut
IES: Inter-Symbol Interference
JPEG: Joint Photographic Experts Group
Li-Fi: Light Fidelity
LOS: Line of Sight
MEG: Magnetoencephalography
MIT: Massachusetts Institute of Technology
MP3: MPEG Audio Layer III
MRI: Magnetic Resonance Imaging
NIH: National Institutes of Health
NRZ: No Return To Zero
NLOS : Non Line of Sight
OOK: On Off Key
OWC: Optical Wireless Communication
PET: Positron Emission Tomography
PHY: Physical Layer
PM: Phase Modulation
PPG: Photoplethysmogram
PWM: Pulse Width Modulation
QCSE: Quantum Confinement Stark Effect
RF: Radio Frequency
RONJA: Reasonable Optical Near Joint Access
SSH: Secure Shell
SWS: Slow Wave Sleep
TDM: Time-Division Multiplexing
UWOC: Under Water Optical Communication

Abbreviations

VLC: Visible Light Communication

VPPM: Variable Pulse Position Modulation

Wi-Fi: Wireless Fidelity

WDM: Wavelength Division Multiplexing

In this project, we are interested by the implementation of an indoor optical wireless communication (OWC) based on visible light communication (VLC) technology for patient monitoring. Monitoring provides a continuous and reliable vital sign measurement to secure patient staying in the hospital. Monitoring allows continuous and reliable measurement of vital signs to secure the patient's stay in the hospital. In this work, the specifications require the implementation of line-of-sight propagation with an OOK modulation system and Manchester coding.

The materiel used to design Indoor VLC Implementation for Medical Healthcare information system is based on two programmable circuits boards RASPBERRY PI 4, for emitting and the other for receiving, an LED as a source of light and a photoresistor to receive light. The programming language is PYTHON.

We have selected RASPBERRY PI 4 for its simplicity but mostly, RASPBERRY PI hardware and software is an open source, which means that the designs and source codes are freely available to use, modify and distribute.

The master's thesis document is organized as follows:

- In chapter one, we will present a general review of a VLC system that will allow us to discover the necessary elements for the implementation of an efficient wireless optical communication system in an indoor environment.
- In chapter two, we will discover medical information systems. We will focus on the vital signals to transmit continuously and that will allow a continuous monitoring of patients remotely.
- Then, in chapter three, we will present the details of the design and experimental implementation of the Indoor VLC Implementation for Medical Healthcare information system.
- Finally, the main observations and analyses of the experimental system will be summarized in the final conclusion.

Chapter I:

Optical Wireless communication Basic Principles

1.1 Introduction

Visible light communication is a subset of optical wireless communication technologies that uses visible light to carry the signal. Typically, LEDs are used as a source of visible light for their high-speed pulsation and throughput.

Optical Wireless Communication (OWC) has attracted many researchers and industrialists around the world, especially since the early 2000s. This interest is understandable given the various applications in the field of wireless transmission and communication [1-4].

In this chapter, we will present some basic notions about light, followed by an explanation of the principle of the visible light communication (VLC) system and finally we will describe the main structure and components used for this technology.

1.2 Visible light in data Transmission

The history of Visible Light Communication dates back to the 1880s, when the Photophone was developed by Alexander Graham Bell, a telecommunication device that was used to transmit a speech on a beam of light. In recent years, different researchers and companies were focused on the development of different solutions based on OWC both for indoor and outdoor applications.

In 2001, RONJA (Reasonable Optical Near Joint Access) a free-space optical communication system was developed and released by *Karel Kulhavý of Twibright Labs*, this system is able to reach a broadband of 10 Mbps for a distance of 1 to 2 kilometres [2].

Where in 2010, a team of researchers from Siemens Company and Fraunhofer HHI organization achieved a transmission at 500 Mbps for a distance of 5 meters, and 100 Mbps for longer distance using LEDs [3].

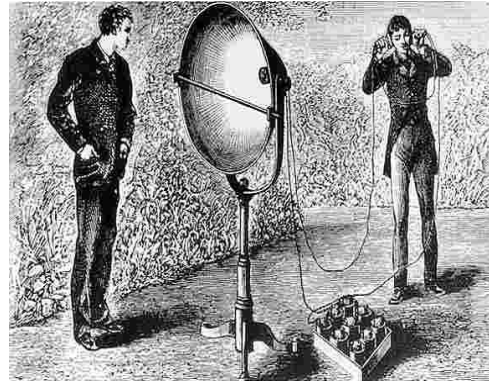

Fig.1.1. RONJA (Reasonable Optical Near Joint Access,[3] Fig1.2. A Photophone receiver and headset,[3]

Hence, using a wireless network gives us the flexibility to access the network without cables. Additionally, it allows us to avoid the expensive process of installing cables in a building.

Visible Light Communication system is a free system with no electro-magnetic interferences that allows us to have a communication at high speed, the RCB LEDs can reach data rate up to 500 Mbps [4].

Visible light communication (VLC) is considered a technology with potentially higher security than traditional wireless methods. This is because visible light, which is the medium of VLC, generally cannot penetrate solid obstacles such as walls, reducing the risk of unauthorized data interception. Unlike radio frequency signals used in conventional wireless technologies, VLC signals are confined to the area directly illuminated by the light source, thus limiting the possibility of interception by unauthorized parties outside this space.

Consequently, the VLC system can be generated with no expensive implementation and without causing any health problems which is also safe to use in hospitals.

1.2.1 OWC based on Visible light

Optical wireless communication (OWC) refers to the use of optic as telecommunication tool but in free space, where the connectivity is based on visible, infrared and ultraviolet bands. Consequently, different area of research are emerged such as indoor visible light communication (VLC) and Light fidelity (Li-Fi), outdoor Free Space Optical Communication (FSO) and Underwater Wireless Optical Communication (UWOC)

In the current project, we are interested by the indoor visible light communication

(VLC) or Light fidelity (Li-Fi). Even if Li-Fi and VLC are closely related terms, often used interchangeably, however, there is a subtle difference between the two terms.

VLC is an optical wireless communication system, it encompasses a wide range of methods and applications beyond just data transmissions using LEDs, it embraces various technologies including Li-Fi [5].

On the other hand, the term Li-Fi was introduced by professor Harald Haas in 2011 at a TED GLOBAL presentation; it involves data transmission at high-speed using LEDs as a light emitter [6].

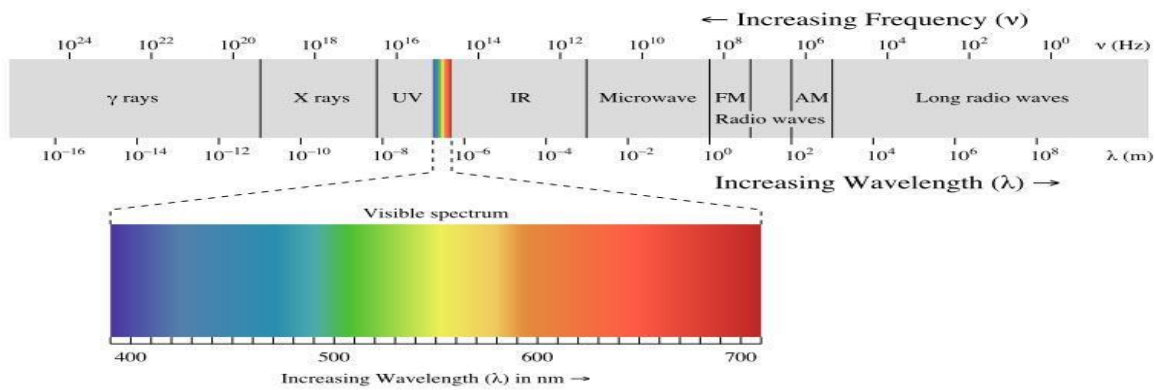

Fig.1.3. Electromagnetic spectrum

However, both methods use visible light. By definition, visible light is a spectrum that covers the wavelength from 380 nm to 750 nm (Figure 1.3), this small part of electromagnetic waves is the spectrum band of the visible light.

1.2.2 Visible light communication (VLC) functional principle

To achieve visual light communication in this prototype, we use the Li-Fi technology, with a white LED bulb to transmit data through constant current lightning; light intensity varies very quickly, sending a binary code, digital 1 when the LED is on and a digital 0 when it's off.

To establish a data transmission system using visible light, we require several components. Firstly, LEDs are utilized as light emitters, coupled with a controller responsible for encoding data into light signals. Conversely, on the receiving end, an image sensor or photodiode functions as a detector to capture the modulated light signals [7].

Within the LED lamp, a microchip is embedded to manage data processing tasks. Data is transmitted by subtly modulating the intensity of light, allowing for the conveyance of information through minor variations in amplitude. This modulation process can be executed

using either a single LED or multiple LEDs, depending on the complexity and requirements of the transmission.

Upon reception, a photodetector intercepts the modulated light signals, converting them into electric signals. These electric signals are subsequently relayed to the connected device for further processing. To ensure compatibility and stability between transmitter and receiver, voltage regulator and level shifter circuits are incorporated on both ends, facilitating the conversion and maintenance of voltage levels throughout the transmission process [8].

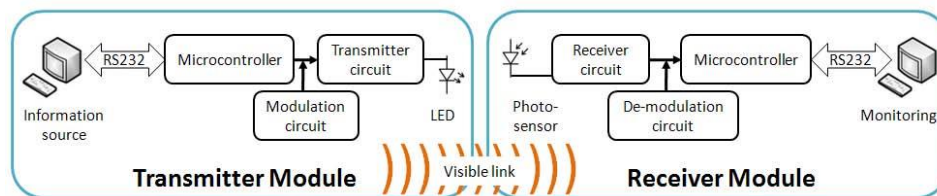

Fig 1.4. Visible Light communication (VLC) block diagram

In figure 1.4, we can observe that VLC block diagram is composed on two main parts namely Transmitter module (Tx) and Receiver Module (Rx) which communicate if free space based on a visible light link.

1.2.2.a) Transmitter (Tx)

The transmitter typically uses **light-emitting diodes (LEDs)** or **laser diodes (LDs)** to convert electrical signals into optical signals.

- a. LEDs are commonly used due to their excellent illumination performance, but limitations like the **quantum confinement Stark effect (QCSE)** and carrier lifetime can impact modulation bandwidth.
- b. Newer light sources like **micro-LEDs (μ -LEDs)** and LDs are being explored to enhance transmission capabilities.

1.2.2.b) Receiver (Rx)

- a. Receives optical signals from the light source.
- b. Specially designed electronic devices containing **photodiodes** (pixels) serve as receivers. In some cases, cell phone, cameras or digital cameras can also capture VLC signals.
- c. The image sensor in these devices can provide either **multi-channel** or **spatial awareness** of multiple light

1.3 Optical Modulation techniques

There is several modulation techniques associated with optical wireless communications. In the context of VLC, the selection of a particular modulation is based on two criteria [9]:

- **Lighting requirements**

Different activities require different illuminations such as 30-100 lux required for normal visual activities in public places.

There is a non-linear relationship between measured light and perceived light, given by equation (1.1):

$$\text{Perceived light (\%)} = 100 * \sqrt{\frac{\text{measured light (\%)}}{100}} \quad (1.1)$$

- **Adaptation to flickering effect**

Changes in the brightness of the modulated light must be made in such a way as to not cause perceptible fluctuations to the human eye. According to IEEE 802.15.7, switching should be done at a rate faster than 200 Hz to avoid harmful effects [10].

In the first IEEE 802.15.7 standard, different modulation types are proposed, including On-Off Keying (OOK), Variable Pulse Position Modulation (VPPM), and Color Shift Keying (CSK). However, many studies have shown the benefits of using multi-carrier modulations such as Orthogonal Frequency-Division Multiplexing (OFDM) [11].

The first three modulations are found in the physical layer (PHY) of the IEEE 802.15.7 standard. PHY types I and II are defined for a single light source and support OOK and VPPM technologies, while PHY III uses multiple optical sources at different frequencies (colors) using CSK modulation [12].

All three systems can coexist, providing attenuation of scintillation and support for dimming, while allowing for a compromise between data rates and dimming ranges.

Visible Light Communication (VLC) utilizes visible light not only for illumination but also as a medium for data transmission, offering a promising alternative for wireless communication. Within VLC systems, several modulation schemes play pivotal roles, each with its distinct characteristics and applications.

1.3.1 OOK Modulation

On-Off Keying (OOK), the simplest modulation technique, operates by switching the light source on and off to represent binary symbols (0s and 1s). OOK boasts straightforward implementation and is well-suited for scenarios with

low data rates. However, its data capacity is limited, and it is susceptible to flickering, albeit with some support for dimming [13].

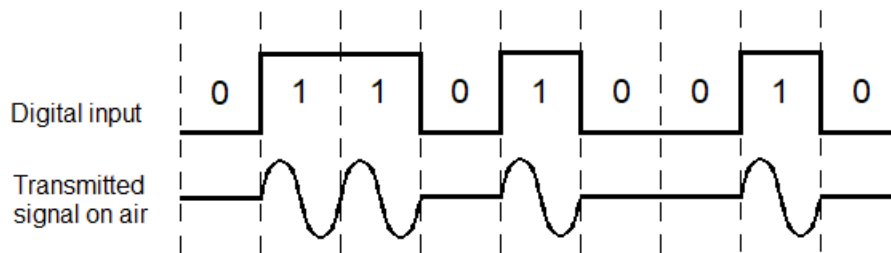

Fig1.5. Example of data transmission on free space

1.3.2 PWM Modulation

Pulse Width Modulation (PWM) modulates the width of light pulses to encode data. Compared to OOK, PWM offers higher data rates and improved robustness. Nevertheless, it demands precise timing synchronization and remains vulnerable to flickering, despite its dimming support [14].

1.3.3 CSK Modulation

Color Shift Keying (CSK) introduces a novel approach by utilizing different colors (wavelengths) of light to represent symbols. CSK facilitates increased data rates compared to OOK and PWM, along with robustness against ambient light interference. However, it necessitates color filters or multiple LEDs, and it presents limitations in terms of available color options and dimming support [15].

1.3.4 GSSK Modulation

Generalized Space Shift Keying (GSSK) employs the spatial positions of light sources to encode data efficiently. GSSK offers the promise of high data rates and robustness against flickering, although its implementation requires precise positioning of light sources and entails complexity. Nevertheless, it provides dimming support [16].

1.3.5 Optical Asymmetric Modulation

Optical Asymmetric Modulation, a newer entrant in the realm of VLC modulation, merges asymmetric pulse position modulation with intensity modulation. This innovative approach yields high data rates and improved robustness. However, its adoption is hindered by the requirement for specialized hardware, despite offering dimming support [17].

For high-speed applications, one quickly faces the problems of source bandwidth limitation as well as IES (Inter-Symbol Interference) generation. To better address these issues, one can use an OFDM modulation.

The principle of this modulation is to consider that data is sent on multiple channels in parallel using different subcarriers. Thus, the time of each symbol corresponding to each subcarrier is much greater than its equivalent for a single carrier, greatly reducing the impact of IES while allowing the bandwidth to be optimized. In summary, each modulation scheme within VLC presents unique trade-offs in terms of data rate, complexity, and robustness. While OOK and PWM cater to simpler implementations with varying degrees of data capacity and susceptibility to flickering, CSK, GSSK, and Optical Asymmetric Modulation offer advancements in data rates and robustness with accompanying challenges such as hardware requirements and limited dimming support. As researchers continue to explore novel techniques, VLC stands poised to address communication challenges while mitigating issues like flickering and dimming in the pursuit of enhanced performance.

1.4 Source coding in OWC

In the literature, different types of source coding are developed both for analogue and digital transmission. In this work, we will present two sources coding techniques used generally for the in wireless digital communication [18].

1.4.1 NRZ (Non-Return-to-Zero) code

The binary data "1" is associated with an optical pulse of duration substantially equal to the symbol time (inverse of the bit rate), and "0" to the absence of a signal. In practice, there is never a total absence of signal since the extinction ratio is never infinite. NRZ coding is used for bit rates below 10 Gbit/s and is used in many 2.5 Gbit/s WDM systems and requires an external modulator [19].

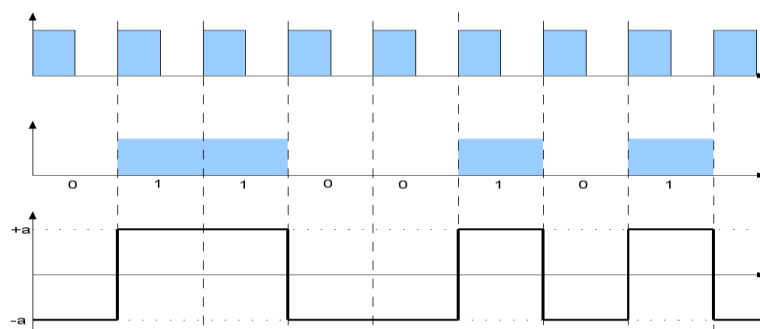

Fig.1.6. Example of Non returns to zero code

1.4.2 Manchester code

Manchester encoding, also known as biphasic encoding, it introduces a transition in the middle of each interval, which means that the "1" data will be encoded by a rising edge in the middle of the clock period, and the "0" data by a falling edge in the middle of the clock period. This is achieved by using an exclusive OR (XOR) between the data signal and the clock signal. The use of this coding eliminates the DC component. Figure I.7 represents the coding of data (1 0 0 1 1 0) in Manchester format [20].

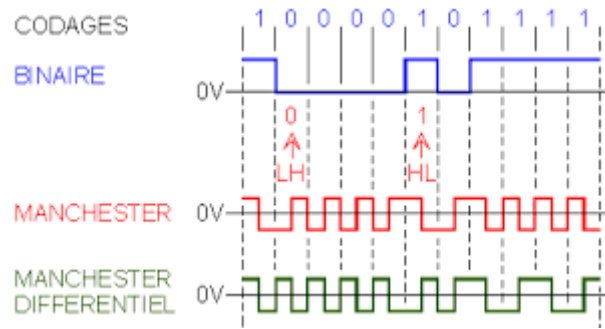

Fig.1.7. Example of Manchester code

1.5 Advantages of indoor OWC

1. **Immunity to Interference:** One of the key advantages of OWC is its immunity to radio frequency interference. Unlike RF technologies, which can be susceptible to interference from various sources such as other wireless devices or environmental factors, OWC operates using visible light, which is not affected by RF interference. This ensures more reliable and stable data transmission, particularly in environments with high RF activity.
2. **Increased Security:** Another significant benefit of OWC is its enhanced security features. Since light waves used in OWC do not penetrate walls, the risk of unauthorized interception of data is greatly reduced. This inherent limitation makes OWC inherently more secure than RF technologies, which can be susceptible to eavesdropping and hacking attempts. As a result, OWC is particularly well-suited for applications where data security is paramount, such as in government, military, and healthcare sectors.
3. **Higher Throughput:** OWC offers significantly higher data transfer rates compared to traditional RF communication technologies. The wider bandwidth of visible light enables OWC to achieve much higher throughput, allowing for faster data transmission speeds and more efficient communication. This increased throughput is particularly advantageous for applications requiring large data transfers or high-definition multimedia streaming, such as video conferencing, streaming services, and

cloud computing.

4. **Affordable Cost:** Despite its advanced capabilities, OWC can be implemented at a relatively affordable cost. One of the primary reasons for this is the ease of integration with existing LED lighting infrastructure. Since LEDs are already widely used for illumination purposes in various settings such as offices, homes, and public spaces, incorporating OWC into these systems requires minimal additional hardware and infrastructure investment. This makes OWC a cost-effective solution for organizations looking to upgrade their communication infrastructure without incurring significant expenses.

1.6 Indoor OWC Applications

Indoor OWC such as Li-Fi represents a cutting-edge wireless optical communication technology leveraging light-emitting diodes (LEDs) for data transmission. Its applications span across diverse sectors, each benefiting from its unique capabilities:

1. **Live Streaming:** Li-Fi's rapid data transmission makes it ideal for live streaming applications. In bustling environments like shopping malls, stadiums, and transportation hubs such as airports and train stations, Li-Fi can provide seamless connectivity for broadcasting events, enhancing visitor experiences, and ensuring real-time communication.
2. **Healthcare Facilities:** The secure and energy-efficient nature of Li-Fi communication renders it highly suitable for transmitting sensitive medical data within hospitals and clinics. From patient records to monitoring equipment, Li-Fi facilitates reliable and high-speed data exchange crucial for efficient healthcare delivery.
3. **Smart Cities:** Integrating Li-Fi into public lighting infrastructure enables the creation of expansive wireless communication networks throughout urban areas. By embedding Li-Fi technology in streetlights, parks, and public spaces, cities can foster connectivity, support IoT applications, and enhance citizen services, paving the way for smarter and more efficient urban living.
4. **Intelligent Transportation:** Li-Fi finds applications in various modes of transportation, including trains, airplanes, and metro systems. By deploying Li-Fi onboard vehicles and at transportation hubs, passengers can enjoy high-speed internet connectivity for entertainment, communication, and productivity, thus enhancing the overall travel experience.

5. **Security:** As an integral component of future communication networks like 5G /6G and IoT, Li-Fi plays a crucial role in ensuring robust security and data privacy. Its inherent characteristics, such as the use of light as the medium for transmission and its immunity to electromagnetic interference, make Li-Fi an attractive option for secure communication in sensitive environments.

In essence, Li-Fi represents a paradigm shift in wireless communication, offering not only unparalleled speed and reliability but also addressing critical challenges such as spectrum congestion and security vulnerabilities. By harnessing the power of light, Li-Fi holds the potential to revolutionize various industries, driving innovation, efficiency, and connectivity in our increasingly interconnected world.

1.7 Conclusion

In this chapter, we have presented a general review of the basic principles of optical wireless communication (OWC) systems, in particular, Visible Light Communication (VLC). We have also explained the block diagram of a VLC system, in which, the basic elements for the realization of a VLC system are presented,

In addition, we have also presented some modulation techniques that are used in optical transmission and the most used source coding techniques in VLC systems.

Moreover, VLC has its own drawbacks, such as limited range, Non Line of Sight (NLOS) and sensitivity to interferences. However, it is still considered as one of the most innovative techniques and deserves to be explored and exploited.

Chapter II:

Medical Information Systems

2.1 Introduction

Medical data is a key kernel of healthcare technology development, improving the diagnostic; creating better treatments, and enhancing patient care. This data encompasses a wide range of information, including patient history, lab results, imaging studies, and treatment plans. Effective management and utilization of medical data can significantly enhance the quality of care provided to patients. In recent years, the healthcare industry has been exploring innovative methods to transmit and receive medical data efficiently and securely. One such method is the use of visible light communication (VLC), a technology that utilizes light-emitting diodes (LEDs) to transmit data [21].

VLC offers numerous advantages in the healthcare setting. First, it provides a high-speed data transmission rate, which is essential for transferring large files such as medical images and patient records quickly. Unlike traditional wireless communication systems, VLC operates in the visible light spectrum, which is not subject to the same interference and bandwidth limitations as radio frequencies. This makes VLC a reliable and efficient method for transmitting medical data in environments where traditional wireless networks may be compromised [22].

Another significant advantage of VLC is its inherent security. Since light cannot penetrate walls, VLC signals are confined to a specific area, reducing the risk of data breaches and unauthorized access. This is particularly important in hospitals, where patient confidentiality and data security are paramount. VLC can ensure that sensitive medical information is transmitted securely within the confines of the hospital, minimizing the risk of data interception.

The importance of Li-Fi, a form of VLC, in hospitals cannot be overstated. Li-Fi technology can transform the way medical data is managed and transmitted within healthcare facilities. In a hospital environment, where the reliability of communication networks is critical, Li-Fi offers a robust alternative to Wi-Fi. It can be used to establish high-speed, secure communication links between medical devices, healthcare providers, and patient monitoring systems. This can lead to improved coordination of care, faster response times, and more accurate real-time monitoring of patient conditions [23-24].

Furthermore, Li-Fi can contribute to reducing electromagnetic interference in hospitals. Many medical devices are sensitive to electromagnetic interference, which can affect their performance and accuracy. Since Li-Fi uses visible light for communication, it does not interfere with medical equipment, ensuring that devices such as MRI machines and cardiac monitors operate without disruption. This can enhance the safety and effectiveness of medical procedures, leading to better patient outcomes [24].

In addition to these benefits, Li-Fi can support the implementation of advanced healthcare technologies such as telemedicine and remote patient monitoring. With the high data transmission rates and secure communication provided by Li-Fi, healthcare providers can

conduct remote consultations, access patient records, and monitor patient health in real-time, regardless of their location. This can be particularly beneficial in rural or underserved areas, where access to healthcare services may be limited.

Consequently, the use of visible light communication, and specifically Li-Fi, in hospitals offers numerous advantages, including high-speed data transmission, enhanced security, reduced electromagnetic interference, and support for advanced healthcare technologies. By integrating Li-Fi into their communication networks, hospitals can improve the efficiency, security, and quality of patient care, ultimately leading to better health outcomes and a more effective healthcare system.

2.2 Overview of Healthcare signals

Physiological signals are vital for diagnosing and monitoring various health conditions. These signals are generated by the body's physiological processes and can be measured using different sensors, each offering unique insights into the body's functioning.

In fact, Human body consists of different types of cells, tissues, and molecules. Due to the exchange of ions and the electrical potential of cells at resting state and during action, bioelectrical signals are generated. These bioelectrical signals correspond to physiological and anatomical aspects of the human body, and could be detected using electronics, optical, and mechanical sensors and transducers placed on the surface of the body.

A more specific definition of a biomedical signal is one that has both amplitude modulation and frequency modulation components. The characteristics of a biomedical signal could be categorized as one that has the following “N” properties: Nonstationarity, Nonlinearity, Non-Gaussian, Near-sparse, and from the data science view point, it could be said as one that has these four “V” properties: Velocity, Variety, Veracity, and Volume [25-26]. Due to the ubiquitous nature of sensors and the rapid advancements in IoT and ICT technologies, it is important to process and analyse the biomedical signals in a more systematic and robust way. It might be beneficial to review some of the common biomedical signals before we get into the details of acquisition, preprocessing, analysis, and decision-making aspects of a connected healthcare system.

2.2.1 Common Physiological Signals

2.2.1.1 Electroencephalogram (EEG) Signals

An electroencephalogram (EEG) is a diagnostic test that measures the electrical activity of the brain, offering a non-invasive way to study brain function. Small, metal discs called electrodes are carefully attached to the scalp to record these electrical signals. The brain's electrical activity, generated by the firing of neurons, is captured and displayed as wavy lines on an EEG recording. These waveforms can be analysed to gain insights into various brain functions and to detect abnormalities that might indicate neurological conditions. EEG is commonly used to diagnose and monitor epilepsy, sleep disorders, brain injuries, and other

neurological issues. It is also utilized in research to study cognitive processes and brain-behaviour relationships. The procedure is safe and painless, typically performed in a hospital or clinical setting. During an EEG, the patient might be asked to perform certain tasks or to rest quietly, depending on the purpose of the test. The recorded signals are examined for patterns and anomalies that reveal the brain's electrical activity under different conditions. By interpreting these patterns, healthcare providers can identify abnormal brain activity, such as seizures or irregular brain waves associated with different neurological disorders. The data from an EEG can guide treatment plans and help in understanding the effectiveness of therapeutic interventions (see figure 2.1). Overall, EEG is a crucial tool in both clinical practice and research, providing valuable information about brain health and function [26-28].

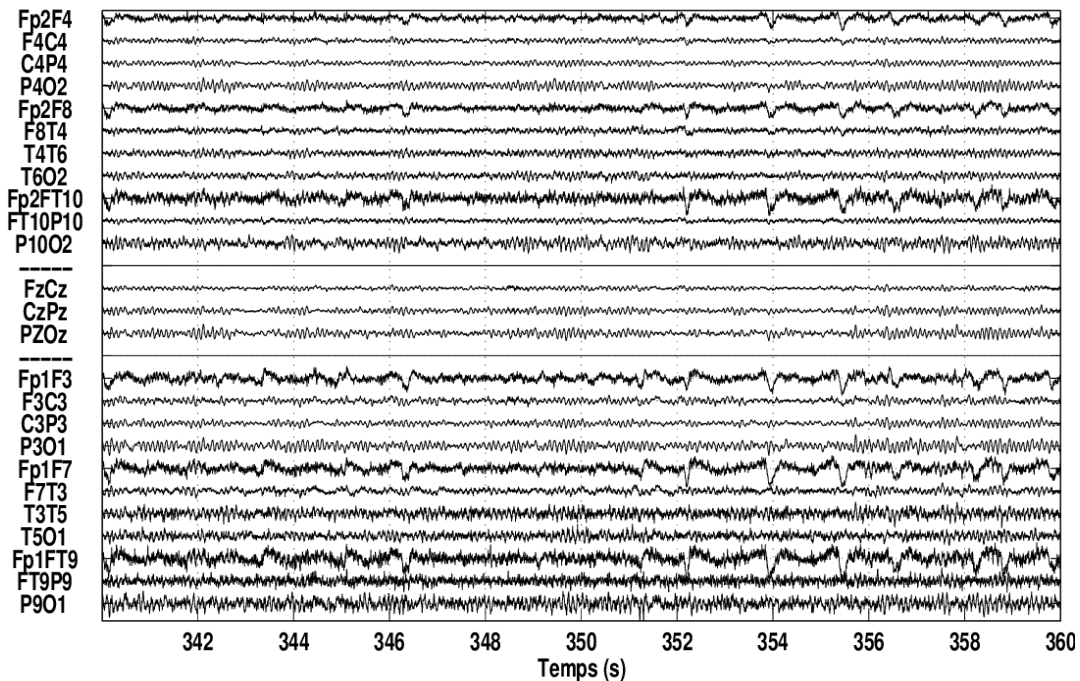

Fig 2.1. Example of EEG Signal, [26].

A. Electronic Components of Electroencephalogram

A.1 Electrodes

Electrodes are small metal discs placed on the scalp to detect electrical activity generated by neurons in the brain. The placement of these electrodes follows a standardized system known as the international 10-20 system, which ensures consistent and reproducible results across different recordings and subjects. This system involves placing electrodes at intervals of 10% or 20% of the total distance between specified anatomical landmarks on the skull. Each electrode location is labelled with letters and numbers corresponding to the brain region and hemisphere it covers (e.g., Fp1 for left frontal pole). The 10-20 system enables a comprehensive and systematic approach to capturing brain activity, ensuring that key regions are monitored effectively. The electrodes are often coated with conductive gel to improve

contact with the scalp and enhance signal quality [26-30].

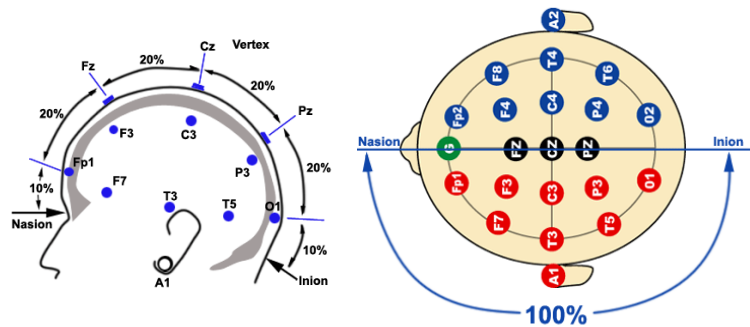

Fig 2.2. 10-20 system of electrode placement [28]
(https://www.medicine.mcgill.ca/physio/vlab/biomed_signals/eeg_n.htm)

A.2 Amplifiers

The electrical signals detected by the electrodes are extremely weak, typically in the range of microvolts. To make these signals suitable for analysis, they need to be amplified. Amplifiers are electronic devices used to increase the strength of these weak signals without distorting them. The amplification process is crucial because it allows for a clearer and more detailed analysis of the brain's electrical activity. Modern EEG systems use differential amplifiers, which amplify the difference in voltage between pairs of electrodes, helping to reduce noise and improve signal quality. The gain of the amplifiers is adjustable, allowing the system to cater to varying signal strengths across different individuals and conditions.

A.3 Filters

Filters are used to remove unwanted noise and artefacts from the EEG signals. Noise can originate from various sources, such as electrical interference from nearby equipment, muscle movements, or external environmental factors. Common types of filters used in EEG systems include low-pass filters, high-pass filters, and notch filters. Low-pass filters allow signals with frequencies below a certain threshold to pass through, removing high-frequency noise. High-pass filters, on the other hand, allow signals with frequencies above a certain threshold to pass through, eliminating low-frequency noise. Notch filters are used to eliminate specific frequency bands, such as the 50/60 Hz power line interference. Filtering is an essential step in signal processing, as it ensures that the recorded EEG data is as clean and accurate as possible, facilitating better analysis and interpretation.

A.4 Analog-to-Digital Converter (ADC)

The amplified and filtered signals from the electrodes are originally in analogue form. To process and analyze these signals using modern digital systems, they must be converted from analog to digital form. An Analog-to-Digital Converter (ADC) performs this conversion by sampling the continuous analog signal at discrete time intervals and quantizing the amplitude values into digital numbers. The sampling rate of the ADC must be sufficiently

high to capture the details of the EEG signals accurately, typically ranging from 256 to 1024 samples per second. The digitized signals can then be stored, processed, and analysed using various computational tools and techniques, allowing for more sophisticated and automated analysis.

A.5 Recording Device

The digital signals obtained from the ADC are recorded and displayed on a computer or other recording device for further analysis. Modern EEG recording devices often include software that provides real-time visualization of the EEG signals, allowing clinicians and researchers to monitor the brain's electrical activity as it is being recorded. These systems also offer tools for annotating, marking events, and segmenting the data for detailed analysis. The recorded data can be stored for long-term monitoring, comparison, and retrospective analysis. Advanced EEG systems may also integrate additional functionalities, such as video recording, to correlate EEG data with behavioural observations.

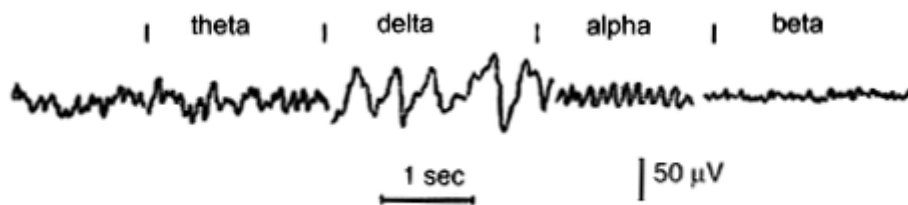

Fig 2.3. EEG Brain Waves, [30].

B. Brain Waves

EEG signals are categorized into different types of brain waves based on their frequency,(figure 2.3) each associated with specific states of brain activity and cognitive functions [30-32].

B.1 Delta Waves (0.5-4 Hz)

Delta waves are the slowest brain waves and are typically associated with deep, restorative sleep, known as slow-wave sleep (SWS). These waves are more prominent in infants and young children, as their brains spend more time in deep sleep for growth and development. In adults, delta waves are also observed during deep meditation and unconscious states. Abnormal delta wave activity can indicate brain injuries, tumors, or other pathological conditions affecting brain function.

B.2 Theta Waves (4-8 Hz)

Theta waves are associated with light sleep, relaxation, and meditative states. They are commonly observed during the transition between wakefulness and sleep, as well as in some stages of sleep. Theta waves are also linked to creativity, daydreaming, and certain types of

learning and memory processing. In clinical settings, excessive theta activity may be associated with attention-deficit hyperactivity disorder (ADHD) or other cognitive disorders.

B.3 Alpha Waves (8-13 Hz)

Alpha waves are prominent when a person is awake but in a relaxed and calm state, especially with closed eyes. They are most evident in the occipital region of the brain. Alpha waves play a role in inhibiting unnecessary brain activity, helping to calm the mind. Reduced alpha activity can be associated with anxiety, stress, or mental fatigue, while increased alpha activity is often seen during relaxation techniques like meditation.

B.4 Beta Waves (13-30 Hz)

Beta waves are associated with active thinking, concentration, and problem-solving. They are most prominent in the frontal and central regions of the brain and are linked to alertness, logical thinking, and focused mental activity. Beta waves increase during cognitive tasks, learning, and social interactions. Abnormal beta activity can indicate conditions such as anxiety, depression, or drug dependence.

B.5 Gamma Waves (30-100 Hz)

Gamma waves are the fastest brain waves and are associated with high-level cognitive functions, such as perception, consciousness, and information processing. They play a crucial role in integrating sensory input, attention, and memory. Gamma activity is often higher during tasks requiring intense concentration and mental effort. Abnormal gamma activity may be related to cognitive impairments, including Alzheimer's disease and schizophrenia.

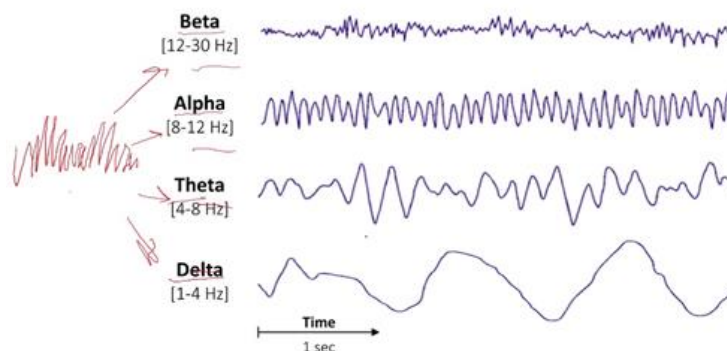

Fig 2.4. EEG frequency bands[33]

C. Applications of EEG

C.1. Medical Diagnosis

EEG is a critical tool in diagnosing and monitoring neurological conditions such as epilepsy sleep disorders, brain injuries, and encephalopathies. By analysing EEG recordings, healthcare providers can detect abnormal brain wave patterns indicative of these conditions, guiding treatment decisions. For example, EEG can identify seizure activity in epilepsy

patients, helping to determine the type and frequency of seizures and monitor the effectiveness of anti-epileptic drugs, [33].

C.2 Research

EEG is widely used in neuroscience research to study brain function, cognitive processes, and neural mechanisms underlying various behaviours and mental states. Researchers use EEG to investigate topics such as attention, memory, language processing, and emotional regulation. The high temporal resolution of EEG allows for precise timing of brain activity in response to specific stimuli, providing valuable insights into the brain's dynamic processes, [34].

C.3 Brain-Computer Interfaces (BCIs)

EEG signals are utilized in brain-computer interfaces (BCIs) to enable direct communication between the brain and external devices. BCIs can help individuals with disabilities control computers, prosthetic limbs, or other assistive devices using their brain activity. For example, a person with severe motor impairments can use a BCI to move a cursor on a screen or operate a robotic arm by generating specific brain wave patterns, enhancing their independence and quality of life, [35].

D. Advantages of EEG

D.1 Non-invasive

EEG is a non-invasive technique, meaning it does not require surgery or insertion of instruments into the body. This makes it safe and suitable for repeated use, even in vulnerable populations such as infants and the elderly.

D.2 High Temporal Resolution

EEG provides real-time monitoring of brain activity with high temporal resolution, typically in the millisecond range. This allows researchers and clinicians to study rapid changes in brain function and capture transient events, such as spikes and bursts associated with epileptic activity.

D.3 Cost-effective

Compared to other neuroimaging techniques like functional magnetic resonance imaging (fMRI) or positron emission tomography (PET), EEG is relatively inexpensive and widely available. This makes it accessible for clinical and research purposes in various settings, including resource-limited environments.

E. Limitations of EEG

E.1 Low Spatial Resolution

EEG has limited spatial resolution, meaning it cannot precisely localize the source of

brain activity within the brain. While it can identify general regions of activity, it is less accurate than techniques like fMRI or magnetoencephalography (MEG) in pinpointing specific neural sources.

E.2 Susceptibility to Artifacts

EEG signals can be affected by various artifacts, such as muscle movements, eye blinks, and electrical noise from surrounding equipment. These artifacts can interfere with the accuracy of the recordings and require careful preprocessing and filtering to minimize their impact.

E.3 Complex Data Analysis

Analysing EEG data requires specialized knowledge and techniques, as the signals are complex and can be influenced by various factors. Advanced signal processing methods, statistical analyses, and machine learning algorithms are often needed to extract meaningful information from EEG recordings. Interpreting these results requires expertise in both neuroscience and data science.

Hence, EEG is a powerful tool for assessing brain activity, with applications ranging from medical diagnosis and research to brain-computer interfaces. Despite its limitations, the non-invasive nature, high temporal resolution, and cost-effectiveness of EEG make it an indispensable technique in both clinical and research settings. Ongoing advancements in technology and data analysis methods continue to enhance the utility and accuracy of EEG, contributing to a deeper understanding of brain function and neurological health [36].

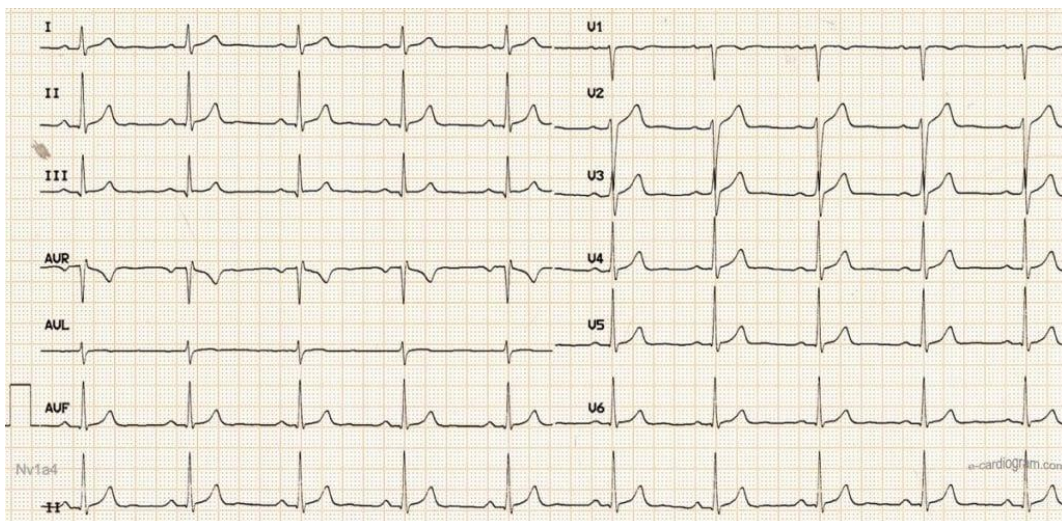

Fig 2.5. Example of an ECG signal recorded, [38].

2.2.1.2 Electrocardiogram (ECG) Signals

An **electrocardiogram (ECG)** records the electrical activity of the heart over a period of time using electrodes placed on the skin. This recording is crucial for diagnosing various heart conditions, including arrhythmias, heart attacks and other cardiac abnormalities [17]

A. Electronic Components of the ECG

A.1. Electrodes

Small, sticky patches placed on the skin to detect electrical activity. Typically, 10 electrodes are used to create a 12-lead ECG, providing a comprehensive view of the heart's activity from different angles.

A.2. Leads

Each lead represents a different angle from which the heart's electrical activity is viewed. The standard 12-lead ECG includes three limb leads (I, II, III), three augmented limb leads (aVR, aVL, aVF), and six precordial (chest) leads (V1-V6).

A.3. Amplifiers

These boost the small electrical signals detected by the electrodes to a level that can be recorded and analysed.

A.4 Filters

Used to remove noise and artifacts from the ECG signal, ensuring a clearer and more accurate recording.

A.5 Recording Device

The amplified and filtered signals are recorded on paper or digitally for analysis.

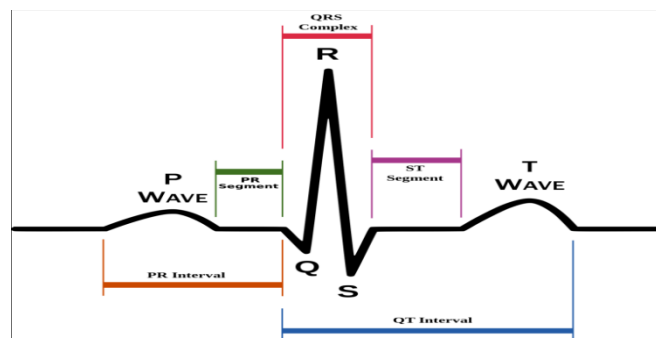

Fig 2.6. ECG Waveform [39]

B. The ECG Waveform

The ECG waveform (figure 2.6) consists of several key components [40]:

B.1. P Wave

Represents atrial depolarization, which is the electrical activity associated with the

contraction of the atria

B.2. QRS Complex

Represents ventricular depolarization, which is the electrical activity associated with the contraction of the ventricles. It consists of:

- **Q Wave:** A small downward deflection.
- **R Wave:** A large upward deflection.
- **S Wave:** A small downward deflection following the R wave.

B.3 T Wave

Represents ventricular repolarization, which is the recovery phase of the ventricles after contraction.

B.4 U Wave:

Sometimes seen following the T wave, its origin is not well understood but is thought to represent repolarization of the Purkinje fibers.

C. Intervals and Segments

1. **PR Interval:** The time from the beginning of the P wave to the beginning of the QRS complex. It represents the time taken for the electrical impulse to travel from the atria to the ventricles (figure 2.6).
2. **QRS Duration:** The time taken for ventricular depolarization. It is measured from the beginning of the Q wave to the end of the S wave.
3. **QT Interval:** The time from the beginning of the QRS complex to the end of the T wave. It represents the total time for ventricular depolarization and repolarization.
4. **ST Segment:** The flat section of the ECG between the end of the S wave and the beginning of the T wave. It represents the period when the ventricles are depolarized.

D. Applications of ECG

1. **Diagnosis of Heart Conditions:** ECG is used to diagnose arrhythmias, myocardial infarctions (heart attacks), and other cardiac abnormalities.
2. **Monitoring Heart Health:** Regular ECGs can monitor the heart's health over time, especially in patients with known heart conditions.
3. **Preoperative Assessment:** ECG is often part of the preoperative assessment to ensure the heart is functioning properly before surgery.
4. **Exercise Stress Testing:** ECG is used during exercise stress tests to evaluate how the heart responds to physical exertion.

E. Advantages of ECG

1. **Non-invasive:** ECG is a non-invasive test, making it safe and easy to perform.
2. **Quick and Painless:** The test is quick, usually taking only a few minutes, and is painless.
3. **Widely Available:** ECG machines are commonly found in medical offices, hospitals, and ambulances.

F. Limitations of ECG

1. **Limited Diagnostic Scope:** While ECG can detect many heart conditions, it may not detect all types of heart disease, especially if the condition is not present during the test.
2. **Susceptibility to Artifacts:** ECG recordings can be affected by various artifacts, such as muscle movements, electrical interference, and poor electrode contact.
3. **Requires Interpretation:** Accurate interpretation of ECG results requires specialized training and experience.

2.2.1.3 Electromyogram (EMG)

The Electromyography (EMG) is a diagnostic procedure used to measure the electrical activity produced by skeletal muscles. EMG signals are crucial for understanding muscle function and diagnosing neuromuscular disorders [41]. It's crucial in sports science, ergonomics, and in monitoring muscle health in conditions like amyotrophic lateral sclerosis (ALS) and muscular dystrophy.

EMG signals are recorded using surface or needle electrodes, reflecting muscle activation, contraction strength, and fatigue. These signals help understand muscle performance and detect abnormal muscle electrical activity

2.2.1.4 Electrooculogram (EOG) Signals

Electrooculography (EOG) is a technique used to measure the electrical potential between the front and back of the eye, which correlates with eye movements. EOG signals are essential for understanding and tracking eye movements in various contexts.

- **Purpose:** EOG signals track eye movements by measuring the electrical potential between the front and back of the eye.
- **Applications:** EOG is used in sleep studies, eye movement research, and to control assistive devices for individuals with disabilities. It helps in diagnosing disorders like nystagmus and in developing human-computer interaction systems.
- **Characteristics:** EOG signals are captured using electrodes placed around the eyes. These signals are influenced by the orientation and movement of the eyes, providing

data on saccades, blinks, and fixation durations.

2.2.1.5 Photoplethysmogram (PPG) Signals

Photoplethysmography (PPG) is a non-invasive method used to measure blood volume changes in the microvascular bed of tissue. PPG signals are widely used in health monitoring and wearable technology [41-42].

- **Purpose:** PPG signals measure blood volume changes in the microvascular bed of tissue.
- **Applications:** PPG is commonly used in wearable devices to monitor heart rate, blood oxygen levels, and vascular health. It's also used in clinical settings to assess circulatory conditions and in telemedicine for remote patient monitoring.
- **Characteristics:** PPG signals are obtained using optical sensors that detect blood flow variations through the skin. The waveform produced provides information on heart rate variability, blood pressure, and respiratory rate.

2.3 Importance of Physiological Signals

Physiological signals provide critical insights into the functioning of the human body. They play an essential role in:

- **Early Diagnosis:**

Detecting diseases at an early stage before symptoms become severe. For instance, ECG can identify early signs of heart disease, and EEG can detect neurological abnormalities.

- **Monitoring:**

Continuously tracking health conditions to observe changes over time. Wearable devices using PPG can monitor heart rate and oxygen levels throughout the day.

- **Treatment:**

- Guiding therapeutic interventions and assessing their effectiveness. EMG can help adjust rehabilitation protocols based on muscle response. **Research:** Advancing medical knowledge and developing new technologies. Physiological signals are foundational in studying human physiology and developing assistive devices

2.3 Medical Signal Processing

Processing physiological signals involves several steps [41]:

1. **Acquisition:** Collecting raw data using sensors. This data often includes various forms of noise and artifacts that need to be addressed.
2. **Filtering:** Removing noise and artifacts to enhance signal quality. Techniques like

bandpass filtering, notch filtering, and adaptive filtering are used to clean the signals.

3. **Feature Extraction:** Identifying key characteristics of the signals, such as peaks, intervals, and frequency components. This step is crucial for interpreting the physiological meaning of the signals.
4. **Analysis:** Interpreting the processed signals to make clinical decisions. This can involve statistical analysis, pattern recognition, and machine learning algorithms.

Advanced techniques like machine learning and deep learning are increasingly being used to analyze physiological signals, improving accuracy and enabling real-time health monitoring [24]. These techniques can automatically detect patterns and anomalies in large datasets, providing more accurate diagnoses and personalized treatment plans. For example, AI algorithms can analyze ECG signals to predict the likelihood of a heart attack, or EEG signals to classify different types of epilepsy [42-43].

2.4 Signal Transmission

Signal processing involves a series of processes designed to prepare a signal for effective transmission, storage, or further processing. These processes ensure that signals are efficiently conveyed across various systems while maintaining their integrity and quality. Here's an in-depth look at the key steps involved [43].

2.4.1 Signal Transmission:

Signal transmission is the process of sending information from one location to another. This can be achieved through different mediums, each with its own set of techniques and technologies:

- **Modulation:** Modulation is the technique of varying a carrier signal to encode and transmit data. There are several common modulation methods:
 - **Amplitude Modulation (AM):** Varies the amplitude of the carrier signal in proportion to the data signal. This method is widely used in AM radio broadcasting.
 - **Frequency Modulation (FM):** Alters the frequency of the carrier signal according to the data signal. FM is used in FM radio and television audio transmissions.
 - **Phase Modulation (PM):** Changes the phase of the carrier signal to represent data. PM is utilized in some digital communication systems and is closely related to frequency modulation.
- **Multiplexing:** Multiplexing combines multiple signals into a single transmission medium to maximize resource utilization and improve efficiency. Two main types of multiplexing are:
 - **Time-Division Multiplexing (TDM):** Divides the transmission time into discrete time slots and allocates each slot to a different signal. This technique

is used in digital telephone networks and data communication systems.

- **Frequency-Division Multiplexing (FDM):** Allocates different frequency bands to each signal within a single channel. FDM is commonly used in analog television broadcasting and radio.
- **Error Control:** To ensure data integrity during transmission, error control mechanisms are employed:
 - **Error Detection:** Methods such as checksums, cyclic redundancy checks (CRC), and parity checks identify errors in transmitted data.
 - **Error Correction:** Techniques like Hamming codes and Reed-Solomon codes correct errors detected during transmission, ensuring that the received data matches the original.

2.4.2 Signal Compression

In Medical data transmission, a stage of compression is required. In fact, signal compression reduces the amount of data needed to represent a signal, which is crucial for efficient storage and transmission. Compression can be classified into two main types [43]:

- **Lossless Compression:** This technique compresses data without losing any information, allowing for exact reconstruction of the original signal. Common methods include:
 - **Huffman Coding:** Uses variable-length codes to represent symbols based on their frequency of occurrence, reducing overall file size.
 - **Arithmetic Coding:** Encodes data by assigning a range of values to each symbol, achieving high compression ratios.
 - **Run-Length Encoding:** Compresses sequences of repeated symbols by storing the symbol and the count of its repetitions.
- **Lossy Compression:** This method reduces file size by removing some data, which may result in a loss of quality but is often acceptable for certain applications. Examples include:
 - **JPEG (Joint Photographic Experts Group):** A widely used method for compressing images, which reduces file size by discarding less important visual details.
 - **MP3 (MPEG Audio Layer III):** A popular format for compressing audio files, which reduces file size by removing audio frequencies that are less audible to the human ear.

2.4.2.1 Analog-to-Digital Conversion (ADC)

Generally, the medical signals are analogic, To transmit signals to the Medical data information systems, the analog signal should be converted to a digital format which

involves several key steps [47-48]:

- **Sampling:** This step involves measuring the analog signal at regular intervals, known as the sampling rate. According to the Nyquist-Shannon sampling theorem, the sampling rate must be at least twice the highest frequency present in the signal to ensure accurate reconstruction of the original signal. For instance, a sampling rate of 44.1 kHz is used for CD-quality audio to capture frequencies up to 22.05 kHz.
- **Quantization:** During quantization, each sampled value is approximated to the nearest value within a finite set of levels. This step introduces quantization error, which is the difference between the actual analogue value and the quantized digital value. The precision of quantization is determined by the number of discrete levels available, which affects the overall quality of the digital signal.
- **Encoding:** The quantized values are converted into binary form, creating a digital representation of the analogue signal. This process involves assigning binary codes to the quantized levels, resulting in a sequence of binary digits (bits) that can be stored, processed, and transmitted by digital systems.

2.5 Conclusion

In this chapter, we have given an overview of the most important medical signals to ensure the monitoring and management of patient health care. We have focused on EEG and ECG signals. In this context, we have discussed the tools needed for signal processing and transmission of EEG and ECG data. Indeed; these two types of signals are special because they form a series of data instead of a single signal. More details will be explained in the experimental part of the transmission of these medical data via the VLC transmission prototype.

Chapter III:

Experimental results

3.1 Introduction

In recent years, the role of wireless communication in the medical field has expanded significantly. Numerous devices, including infusion pumps, ventilators, and anaesthesia machines, now operate over Wi-Fi. However, when integrating both magnetic resonance imaging scanners and Wi-Fi-dependent infusion pumps, frequency interference can occur. The growing prevalence of wireless medical devices increases the demand for radiofrequency (RF) spectrum, leading to electromagnetic interference (EMI) that may compromise the performance of medical equipment and patient safety [35]

Another challenge with Wi-Fi in healthcare settings is the need to protect patient information while ensuring it is accessible to authorized personnel. Hospitals face significant concerns regarding EMI and the security of sensitive medical data when relying on Wi-Fi. To address these issues, Visible Light Communication (VLC) offers a promising alternative. VLC is a cutting-edge technology that provides high-density wireless data coverage and minimizes radio interference in confined spaces [44].

In this chapter, we will focus on designing a VLC-based communication system to enhance and strengthen the medical information data system. The objective of this project is to develop a healthy wireless communication system that enables efficient data exchange in real time. This system will facilitate patient monitoring and control in a hospital environment, using visible light-based simplex communication. Our proposed system ensures that data transmission and reception occur seamlessly without modifying existing system designs.

3.2 VLC design and diagram

Digital transmission systems facilitate the transfer of information from the transmitter to the receiver via various media, including cables, optical fiber, and electromagnetic waves. In the case of Visible Light Communication (VLC) or Li-Fi, the medium of transmission is light.

Figure 3.1 illustrates a basic digital transmission system's block diagram. The process begins with the transmitter, which generates the message to be sent. This message undergoes encoding and modulation to prepare it for transmission through the communication channel. On the receiving end, the transmitted signal is demodulated and decoded, allowing the recipient to interpret the message accurately.

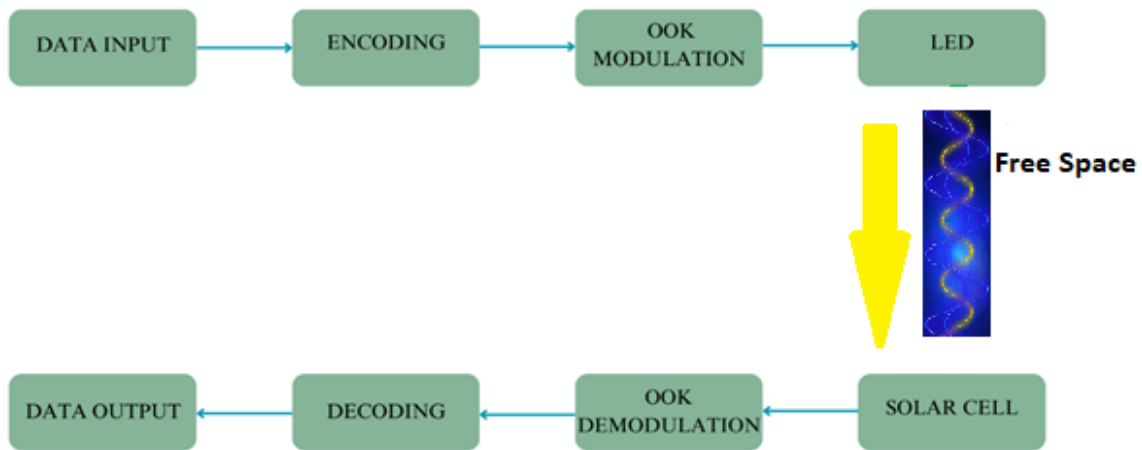

Fig.3.1. Schematic diagram of a simplex digital transmission system

3.2.1 Materials and software

3.2.1.1 Micro-processor (Raspberry Pi 4)

A Raspberry Pi is a small computer (85 mm x 56 mm is the standard size), It looks like a PC motherboard, but all the components are already on it (CPU, memory, wireless module, USB, network, etc.) [45-46].

The only thing that is not included on the main board is the storage. There is no built-in hard drive, but there is a micro-SD card slot on the back of it and USB drives are supported. So, we need an additional SD card and all the cables.

The figure below is a Raspberry Pi 4.



Fig.3.2. Raspberry Pi 4 Card

3.2.1.2 SD Card

In order to perform on the raspberry pi 4, we need two SD cards to boot the system and to create and save files and coding.

We are using two 32GB SD cards.



Fig 3.3 Example of 32 GB SD card

3.2.1.3 Raspberry pi 4 Software

The Raspberry Pi 4 is a versatile tool that supports a wide range of programming languages, making it ideal for various projects. Here are some of the most commonly used languages [46]:

Python: This is the most popular language for Raspberry Pi projects. It's pre-installed on Raspberry Pi OS and has strong support for interfacing with the Pi's hardware, including GPIO pins, cameras, and HATs.

C++: These languages are ideal for performance-critical applications and come with default support on the Raspberry Pi.

Scratch: A beginner-friendly language, Scratch is particularly useful for educational purposes and those new to programming.

JavaScript (Node.js): This language is useful for web development and server-side applications on the Raspberry Pi.

Java: A versatile language that can be used for a wide range of applications on the Raspberry Pi.

Additionally, we can install other languages like Ruby, Perl, and more, depending on the requirements of any project. In this final master's degree project, we are using Python.

Some other softwares are used, such as:

- Filezilla is a software that allows us to connect and transfer files remotely through IP addresses to devices.
- EDFbrowser which is software that opens EDF files to read, analyse and edit signals, and
- Putty, to access the Raspberry Pi using the headless method (SSH)

3.2.1.4 Raspberry pi 4 access

SSH (Secure Shell) on the Raspberry Pi 4 enables remote control and management of our device from another computer, which is especially useful for headless setups without a monitor or keyboard. It allows us to execute commands, transfer files, and manages our Raspberry Pi remotely, making it easier to work on projects without needing physical access to the device. SSH enhances the flexibility and usability of the Raspberry Pi 4, particularly for remote development and administration tasks [46].

3.2.1.5 Arduino Board

The UNO model from the ARDUINO company is an electronic board whose core is a microcontroller with the reference ATmega328. The ATmega328 is an 8-bit microcontroller from the AVR family, and its programming can be done in the C/C++ language...

In this project, the Arduino UNO Microcontroller Board (Figure 3.4) is used as Analogue to Digital Converter (ADC) in the receiver part of the Indoor OWC system. It works also as a detector of level 1 and 0.

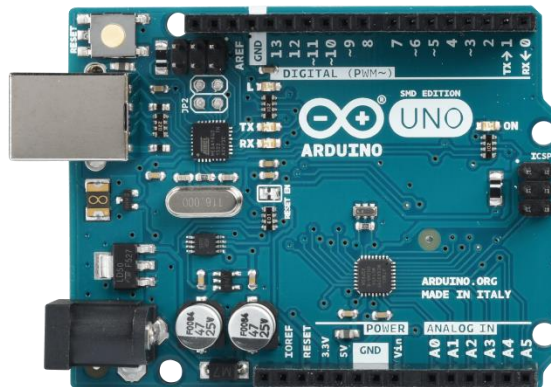

Fig 3.4 Arduino UNO Board

3.2.1.6 LED

An Electroluminescent Diode (LED) is a semiconductor device consisting of two conductors. It operates as a PN junction diode and emits light when powered. In the following experiment, we have used for the data emission; a high-power White LED module rated at 3 watts. [6]



Fig 3.5 The Electroluminescent Diode (LED) used in the experimental prototype

The technical characteristics of the LED used are as follows: - Color temperature: warm white 3000-3200K / white 6000-6500K

- Forward current: 700 mA
- Luminous flux: White 180-200 Lux (Lumens)
- Forward voltage: 3.3 - 3.6 V
- Reverse voltage: 5V
- Power: 3W
- Viewing angle: 180°

3.2.1.7 Photodetector

In this experiment, we have used a Photovoltaic cells used as receiver for the establishment of an indoor Visible Light Communication (VLC), where it allow to convert light into electrical signals. They harness photon energy to excite electrons in the semiconductor, creating electron-hole pairs. An internal electric field separates these charges, generating a varying electric current in response to the modulated light signal. By detecting these current changes, the data encoded in the visible light can be effectively retrieved. This use of photovoltaic cells in VLC allows for efficient and sustainable data transmission using visible light.



Fig3.6. Example of Photovoltaic cell

3.3 Indoor VLC system design and experiment

The Indoor VLC system is composed mainly of two parts: Transmitter (Tx) and receiver (Rx). In the following paragraphs, we will explain each part as well as the interconnection between (Tx) and (Rx).

3.3.1 Indoor VLC Transmitter (Tx)

The transmitter side of the indoor VLC/Li-Fi system consists of Raspberry pi 4 health data information processing to send to LED's for transmitting binary data over the free space.

Data sources (figure 3.1) are generated, encoded and modulated inside the Raspberry. The Modulation used in our project is the OOK modulation where the variation of the data is a function of the light intensity of the transmitting LED

The transmitter circuit is illustrated in figure 3.7:

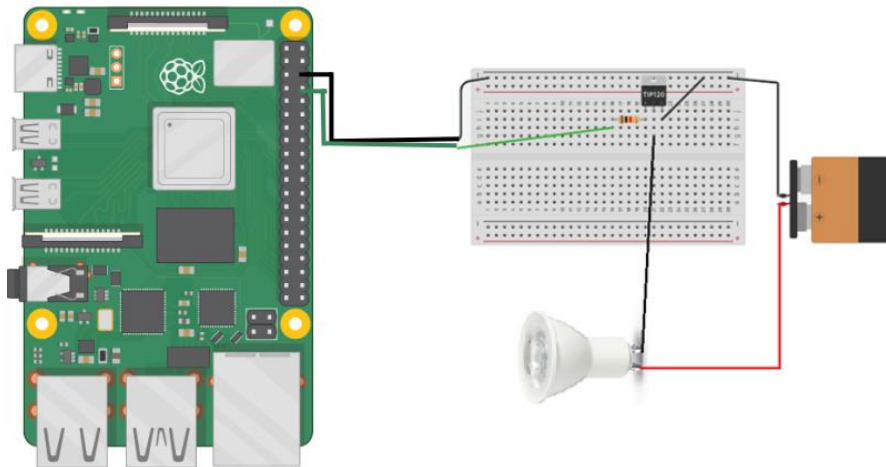

Fig3.7. Transmitter part of the Indoor VLC system

3.3.2 Indoor VLC Receiver (RX)

The receiver side of the indoor VLC system is composed of:

- The photovoltaic cell as a detector of the luminous intensity which will be converted into current, however, the variations of the latter are analogical
- An Arduino Uno which will ensure both the analog-digital conversion, and the detection of the level of 1 and 0
- A second Raspberry pi 4 which will ensure the processing of digital data.

In figure 3.6, we illustrate the interconnection of the reception circuit.

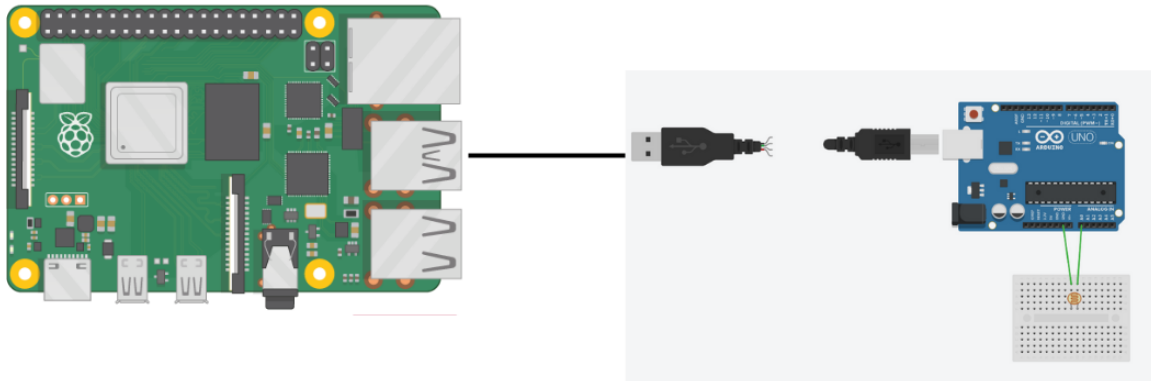

Fig3.8. Experimental design of the receiver in the of the Indoor VLC system

3.4 Data transmission and synchronization

3.4.1 Data transmission

The data transmission in our setup using visible light communication (VLC) with an LED and a solar cell works by converting data (text or signal) into a sequence of binary bits and then sending these bits through the LED over a free space.

The first step involves converting the text and/or signal data into a binary format. The transmitter (Raspberry Pi) sends the binary data bit by bit serially by turning on and off the LED. For example, if the raw binary data is 100110111100, the LED illumination and extinction diagram is illustrated in figure 3.9.

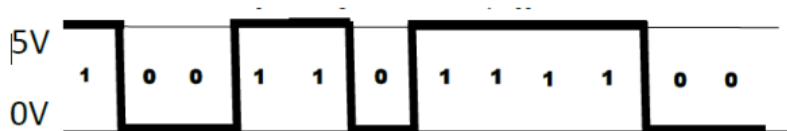

Fig3.9 Example of a binary sequence presented by the LED

3.5 NRZ Encoding

NRZ (Non-Return-to-Zero) encoding which is used in our experience is a binary data transmission method where the signal level is directly related to the value of the bit being transmitted, without any return to a baseline or "zero" level between bits.

In NRZ, a logical 1 is represented by one voltage level (usually a high voltage), and a logical 0 is represented by another voltage level (usually a low voltage).

3.6 Communication Protocol

In this project, the transmission is based on the IEEE 802.15.7 standard, “Short-Range Optical Wireless communication which defines wireless communication using visible light.

This standard describes how data is transmitted, modulated and organized to enable reliable and efficient communication in various environments. The standard is designed to work with other wireless communication systems and supports both Line-Of-Sight (LOS) and Non-Line-Of-Sight (NLOS) Communications.

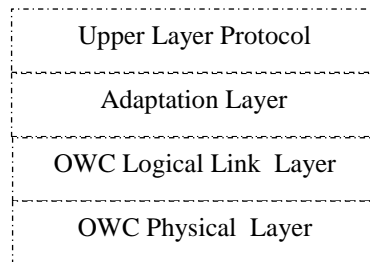

Fig 3.10. Short-Range Optical Wireless Communications Layers

The transmission protocol in experimental indoor OWC system is presented in the Figure 3.11. We should notice that the transmission is made in simplex mode.

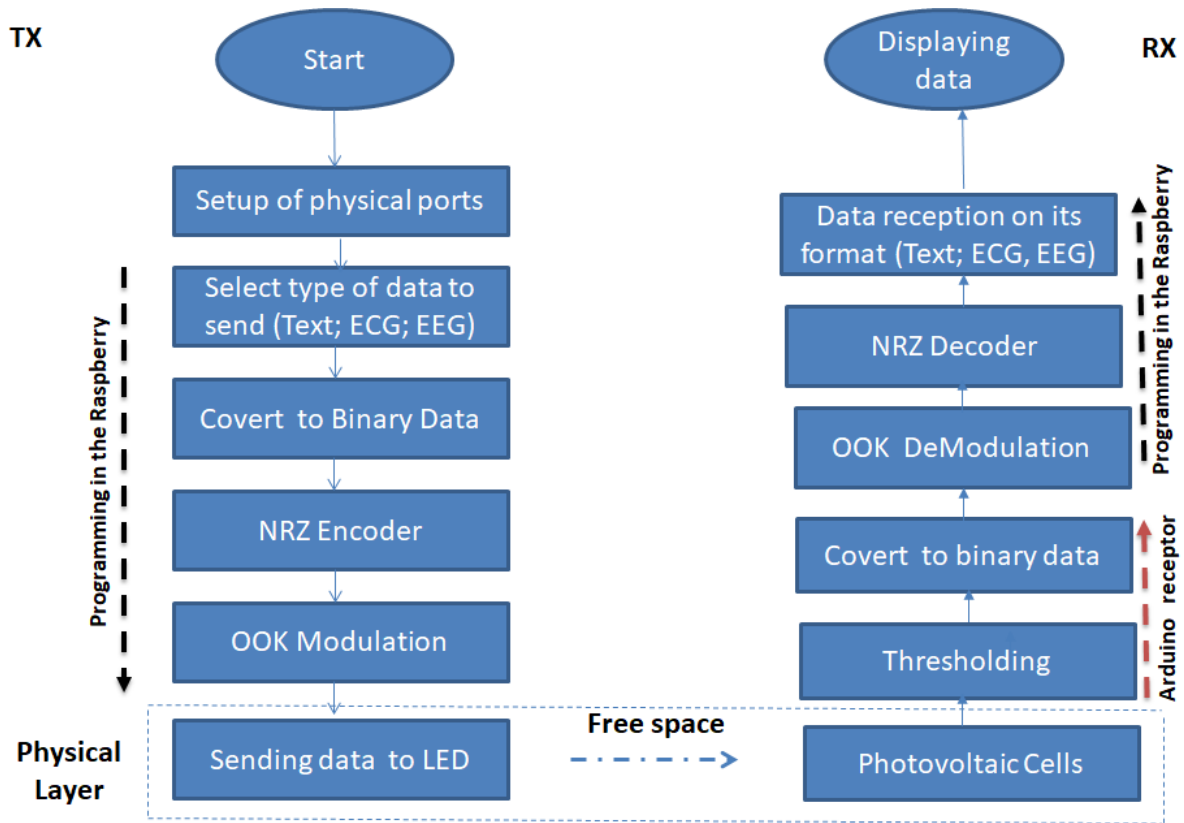

Fig 3.11. Indoor OWC system communication protocol

3.6.1 Data synchronization between transmitter and receiver

Data synchronization ensures that the transmitter (LED) and the receiver (solar cell) are aligned in both timing and data structure. Synchronization is crucial because the receiver must know when the actual data starts and ends, and it must sample the signal at the correct time to avoid missing bits or misinterpreting the message [48].

The first aspect of synchronization is timing; the transmitter and receiver need to operate on the same clock, meaning they need to be sampling and sending bits at the same rate.

In addition to timing, you also need to ensure that the start and end of the transmission are identified correctly. This is achieved using special markers, the Start of Transmission (SOT) and End of Transmission (EOT) markers.

3.6.2 Data Transmission

The transmission Process (Tx) should prepare and establish a protocol for transmission according to the IEEE 802.15.7 standard described already in figures 3.10 and 3.11 standard. Hence, after the finalisation process of data (Figure 3.10), the data should be organised in a specific format called a frame (see Figure 3.12).



Fig 3.12 Transmission frames composition

In this project, we consider 3 bits for the Start of Transmission (SOT), followed by the message and 3 bits for the End of Transmission (EOT).

The same composition of the frames should be considered at the receiver level.

3.6.2 Data Reception

At reception physical layer, it is important recalibrate the detection threshold of bit '1' and bit '0'. At each period, we have to set up the receiver threshold according to the environment, the ambient light and random disturbances.

In fact, the detection threshold represents the average peak voltage difference caused by ambient light and the random disturbances. In this project, we use an Arduino program to calculate this threshold. The Arduino compares the received voltage difference with the threshold value. If the received voltage is higher than the threshold, it's considered a high peak (bit '1'), and if it's lower, it's considered a low peak (bit '0'). By doing this, the Arduino converts the analogue data from the received signal into digital data. This process allows the receiver to detect variations in ambient light and convert them into digital information for further processing in the project.

For adaptive detection of the detection threshold, the algorithm consists of:

- a. Sending a sequence of pilot bits of a fixed size.
- b. Calculation of the separation threshold between the level of bit '1' and that of bit '0':

On reception side, the detection threshold is equal to mean value of the fixed size of the pilot bits.

The equations (3.1) and (3.2) represent computation of the threshold and the bit detection principle.

$$\text{Threshold} = \frac{\sum_{i=1}^n \text{Value}(i)}{n} \quad (3.1)$$

$$\text{Bit} = \begin{cases} 1 & \text{if the received value} \geq \text{Threshold} \\ 0 & \text{if the received value} < \text{Threshold} \end{cases} \quad (3.2)$$

The reception algorithm is presented in the figure 3.13

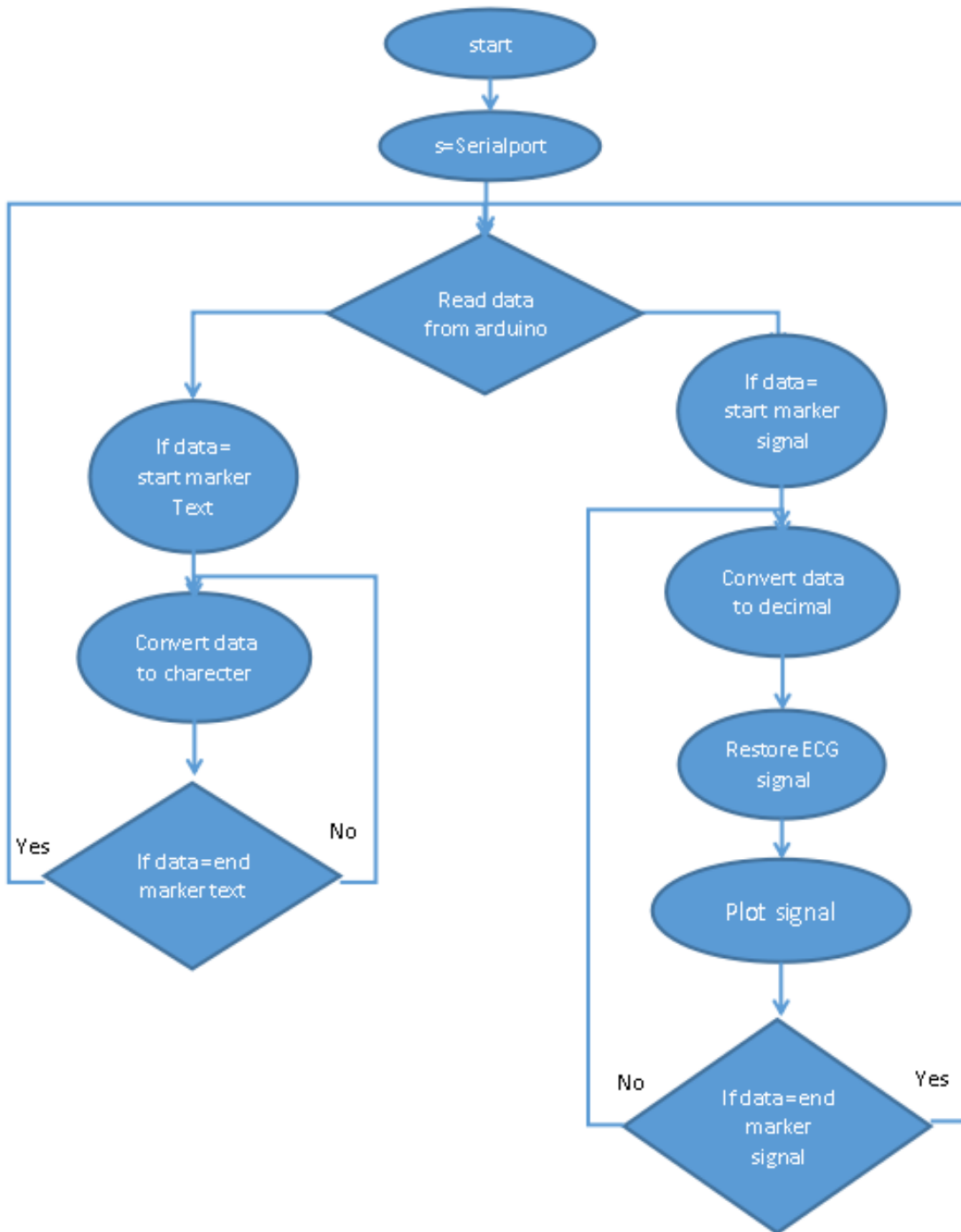

Fig3.13. Reception diagram

3.7 Experimental results

In data transmission through visible light, the transmission process involves converting digital data into a form suitable for optical communication. If we consider the text transmission, we have to use ASCII encoding to represent characters as binary values. For example, the text "Faculty of science and technology" consists of 35 characters. Each character is mapped to an 8-bit binary code according to the ASCII standard.

To facilitate the transmission of this binary data through visible light, Non-Return-to-Zero (NRZ) encoding is employed. In NRZ encoding, binary '1's and '0's are represented by two distinct light states. For example, the binary representation of the letter 'F' in ASCII is 01000110, where '0's are represented by the light OFF state and '1's are represented by the light ON state. Thus, the light intensity will switch between ON and OFF states to match the binary sequence of each character. By combining ASCII encoding with NRZ encoding, our system effectively encodes and transmits digital information through visible light, ensuring reliable and efficient communication. This process allows the transmission of complex messages, such as "Faculty of science and technology," by accurately converting and sending the entire 280-bits sequence via visible light with the respect of the organisation of transmission and reception frames (see Figure 3.12 and Figure 3.13)

In Figure 3.14, the experimental prototype is presented; we can observe the LED transmission of the numerical data, where in figure 3.15, we can observe the text transmission and reception.



Fig.3.14. Experimental prototype

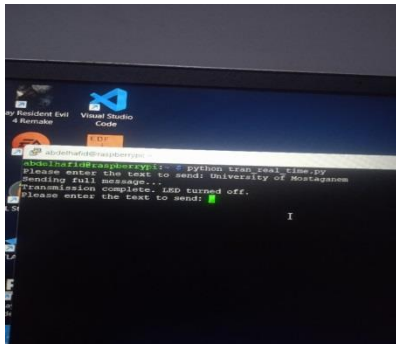

(a) Transmitter

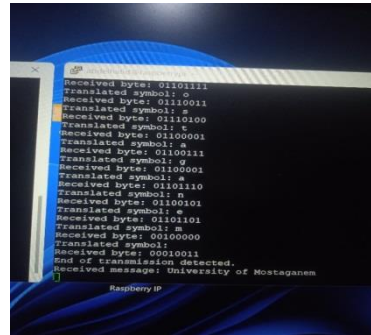

(b) Receiver

Fig 3.15. Transmission process of the Text

In table 3.1, we present the BER and the Bit rate for transmission of the text « University of Mostaganem » through the experimental indoor VLC system

Table 3.1 Performance evaluation of Text transmission

Distance	Delay	BER	Bitrate
20cm	0.1s	0	10bps
20cm	0.05s	0	20bps
20cm	0.04s	0	25bps
50cm	0.1s	0	10bps
50cm	0.05s	0	20bps
50cm	0.04s	0	25bps
80cm	0.1s	0	10bps
80cm	0.05s	0.04	20bps
80cm	0.04s	0.06	25bps

3.7 Results discussion and Performance improvement

In this prototype, we have observed that the solar cell used is a low-speed photodetector, which limits the performance of the VLC system and does not really exploit the advantages of high-speed light transmission. We searched for another photodetector, it turns out that the S5973 (Si PIN photodiode) has a very fast switching time, therefore, it is a high-speed detector designed for visible to near-infrared light detection. This photodiode offers broadband characteristics with low bias, making it suitable for optical communications and other high-speed photometry.

3.8 Conclusion

By implementing VLC in hospitals and medical field, many problems would be solved, such as Wi-Fi interference with electromagnetic devices and instruments, data security, and avoiding harmful electromagnetic fields.

In the indoor VLC experimental system proposed in this project, we used Raspberry pi 4 because of its performance. Indeed, it allows us to achieve higher bit rate, more flexible access, and thanks to its large buffer, better performance could be obtained.

However, we did not achieve the second goal mentioned in the specification which concerns the transmission of serial data such as EEG or ECG, in addition, the transmission rate is still low. In the future, the experimental prototype can be improved by using a suitable high-speed photodetector.

In this work, we have tried to design and implement an experimental system for indoor optical wireless communication (OWC) based on visible light communication (VLC) technology for Medical Healthcare information.

The proposed system utilizes two programmable circuits boards RASPBERRY PI 4, for data transmission and data reception, an UNO ARDUINO as an analogue to digital converter, a LED as a light transmitter sensor and photovoltaic cells as a light converter.

The programming language is PYTHON and the specifications require the implementation of line-of-sight (LOS) propagation with an OOK modulation system and Manchester coding.

In this experiment, the circuit board RASPBERRY PI 4 is the key kernel of data processing, encoding and modulation because of its performance. It allows us to achieve higher bit rate, more flexible access, with large buffer. Hence, better performance could be obtained.

However, we have encountered some technical problems such as:

- Low frequency of bit detection
- Need to add a microcontroller for an adaptive detection of the bit: level '1' and '0'
- Need to add an analog-to-digital converter

As a result, we did not achieve the second goal mentioned in the specification which concerns the transmission of serial data such as EEG or ECG.

In the future, the experimental prototype can be improved by using a suitable high-speed photodetector for transmission of a big rate data as well as transmission of diverse type of data and images. We should also focus on the design of the organization of software that manage the medical health information system.

References

- [1] M. Uysal, M. A. Khalighi, *Optical Wireless Communications – An Emerging Technology*, ICTON (International Conference on Transparent Optical Networks), July 2014.
- [2] Karel Kulhavý, *RONJA (Reasonable Optical Near Joint Access)*, Twibright Labs, 2001.
- [3] Alexander Graham Bell, *Photophone*, 1880s ([Wikipedia](#))
- [4] K. M. M. Ali, M. S. A. Rashid, and I. M. Ali, "Visible Light Communication: A Comprehensive Survey," *IEEE Communications Surveys & Tutorials*, 2018.
- [5] R. B. S. F. R. Mendes, F. J. de Lima, and J. J. P. C. Lima, "Li-Fi: A New Optical Wireless Communication Technology," *Journal of Optical Communications and Networking*, 2019.
- [6] H. Haas, "Li-Fi is a new way to wireless communication," TED Global, 2011.
- [7] A. M. Al-Obaidi, S. A. M. Al-Hadhrami, and A. B. J. S. B. A. O. A. Ali, "Visible Light Communication Systems: A Review," *Journal of Optical Communications and Networking*, 2021.
- [8] I. F. Akyildiz, H. Sankaran, and M. C. L. Y. Chen, "The Role of Photodetectors in Visible Light Communication Systems," *IEEE Access*, 2020.
- [9] A. K. Gupta, H. R. Goyal, and V. B. Patil, "Modulation Techniques for Visible Light Communication: A Review," *International Journal of Computer Applications*, 2018.
- [10] IEEE 802.15.7-2011, "IEEE Standard for Local and Metropolitan Area Networks: Part 15.7: Short-Range Wireless Optical Communication Using Visible Light," IEEE, 2011.
- [11] A. S. M. M. A. Rahman, M. R. R. M. Z. K. H. A. M. Ahmed, and A. A. N. M. J. A. N. S. Al-Mamun, "A Survey on Modulation Techniques for Visible Light Communication," *Journal of Optical Communications and Networking*, 2020.
- [12] M. R. H. U. M. R. Al-Mamun, S. M. U. S. Shahriar, and H. J. M. S. F. Rahman, "Analysis of Modulation Techniques in IEEE 802.15.7 for Visible Light Communication," *IEEE Access*, 2019.
- [13] S. Y. M. S. Y. Y. H. S. Y. C. P. H. M. Chen, "A Survey of Modulation Techniques for Visible Light Communication," *Journal of Communications and Networks*, 2018.
- [14] M. A. M. A. Rahman, R. M. A. A. Faruk, and A. M. Al-Mamun, "Pulse Width Modulation for Visible Light Communication: Challenges and Solutions," *Journal of Optical Communications and Networking*, 2020.
- [15] M. R. H. U. M. Rahman, A. K. Gupta, and S. A. Y. A. K. A. M. A. N. K. Ali, "Color Shift Keying Modulation for Visible Light Communication: A Review," *IEEE Access*, 2021.
- [16] Z. Zhang, Y. Zhang, and C. Xu, "Generalized Space Shift Keying for Visible Light Communication: Principles and Applications," *IEEE Transactions on Communications*, 2020.
- [17] S. A. A. Alhassan, M. R. Al-Mamun, and A. A. Al-Mukhtar, "Optical Asymmetric Modulation for Visible Light Communication: A Review," *Journal of Lightwave Technology*, 2021.
- [18] A. M. Alsharif and M. M. S. El-Hadidy, "Source Coding Techniques in Wireless Digital Communication: A Survey," *International Journal of Computer Applications*, 2020.
- [19] G. P. Agrawal, "Fiber-Optic Communication Systems," 4th ed., Wiley, 2012

References

- [20] B. Sklar, "Digital Communications: Fundamentals and Applications," 2nd ed., Prentice Hall, 2001.
- [21] A. I. A. Al-Hazmi, M. A. M. Alghamdi, and M. A. A. H. Alhassan, "Visible Light Communication in Medical Applications: A Survey," *IEEE Access*, 2020
- [22] M. Kavehrad, "Sustainable Energy-Efficient Wireless Applications Using Light," *IEEE Communications Magazine*, 2010.
- [23] H. Haas, "LiFi: The Future of Wireless Communication," *IEEE Communications Magazine*, 2015.
- [24] M. R. K. M. U. M. A. R. Rahman, S. R. M. A. K. Al-Ali, and N. S. A. Ahmed, "Impact of Li-Fi Technology in Healthcare: Opportunities and Challenges," *IEEE Access*, 2021.
- [25] J. G. Webster and L. A. Neuman, "Medical Instrumentation: Application and Design," 4th ed., Wiley, 2016
- [26] S. Niedermeyer and F. L. da Silva, "Electroencephalography: Basic Principles, Clinical Applications, and Related Fields," 5th ed., Lippincott Williams & Wilkins, 2004.
- [27] https://www.medicine.mcgill.ca/physio/vlab/biomed_signals/eeg_n.htm
- [28] G. L. da Silva, "Brain Waves: The Role of EEG in Clinical Practice," *Clinical Neurophysiology*, 2018.
- [29] L. H. S. S. H. K. S. G. W. S. Wang, "The Role of EEG in the Diagnosis and Treatment of Epilepsy," *Journal of Clinical Neurophysiology*, 2020.
- [30] T. C. H. A. H. D. M. J. D. M. P. S. S. H. D. R. H. L. D. H. K. M. H. M. G. T. B. E. G. P. L. P. "EEG as a Tool in Cognitive Neuroscience," *Nature Reviews Neuroscience*, 2019.
- [31] N. Lebedev and M. I. Nicolelis, "Brain–Machine Interfaces: Past, Present, and Future," *Trends in Neurosciences*, 2006
- [32] D. G. A. B. E. B. R. R. H. G. H. S. R. L. H. H. H. A. M. "Advances in EEG Technology and Applications: A Review," *Frontiers in Neuroscience*, 2021
- [33] C. A. Surawicz and D. M. Knilans, "Chou's Electrocardiography in Clinical Practice," 6th ed., Elsevier, 2008.
- [34] <https://www.avf-biomedical.com/app/uploads/2022/01/ECG-normal-trace-1024x500.jpg>
- [35] G. K. A. R. W. S. A. H. P. Z. J. B. E. S. "The ECG Made Easy," 8th ed., Elsevier, 2013.
- [35] E. S. N. M. J. L. P. "Electromyography: Physiology, Engineering, and Non-Invasive Applications," Wiley-IEEE Press, 2004.
- [36] J. Allen, "Photoplethysmography and Its Application in Clinical Physiological Measurement," *Physiological Measurement*, 2007
- [37] M. Akay, "Biomedical Signal Processing," Academic Press, 1994
- [38] F. S. H. S. M. J. M. A. C. E. "Deep Learning for Healthcare: Opportunities, Challenges and Applications Using Physiological Signals," *IEEE Access*, 2020.
- [39] M. A. J. S. H. S. K. M. "Artificial Intelligence in Cardiology and Neurology: Predictive Analytics Using ECG and EEG Signals," *Journal of Medical Systems*, 2019.

References

- [40] S. K. Mitra, "Digital Signal Processing: A Computer-Based Approach," 4th ed., McGraw-Hill, 2010.
- [41] A. M. M. G. "Signal Compression in Biomedical Signal Processing," IEEE Transactions on Biomedical Engineering, 1998. [Link](<https://ieeexplore.ieee.org/document/730644>).
- [42] J. G. Proakis and D. G. Manolakis, "Digital Signal Processing: Principles, Algorithms, and Applications," 4th ed., Prentice Hall, 2006. [Link](<https://www.pearson.com/store/p/digital-signal-processing-principles-algorithms-and-applications/P100000207884>).
- [43] A. Uribe, K. M. Nguyen, and J. H. Reed, "Electromagnetic Interference in Wireless Medical Devices: A Growing Concern," IEEE Engineering in Medicine and Biology Magazine, 2012. [Link](<https://ieeexplore.ieee.org/document/6129082>).
- [44] H. Haas, "Wireless Data from Every Light Bulb," IEEE Spectrum, 2013. [Link](<https://spectrum.ieee.org/wireless-data-from-every-light-bulb>).
- [45] E. McMahon, "Raspberry Pi Cookbook: Python Programming and Raspberry Pi Projects," 3rd ed., O'Reilly Media, 2019. [Link](<https://www.oreilly.com/library/view/raspberry-pi-cookbook/9781492055066/>).
- [46] D. A. Smith, "Raspberry Pi User Guide," 4th ed., Wiley, 2016. [Link](<https://www.wiley.com/en-us/Raspberry+Pi+User+Guide%2C+4th+Edition-p-9781119282700>).
- [47] S. M. Sze and K. K. Ng, "Physics of Semiconductor Devices," 3rd ed., Wiley-Interscience, 2006.
- [48] S. Haykin and M. Moher, "Communication Systems," 5th ed., Wiley, 2009.